

AC POWER SUPPLY

PSH300A

Enclosed 300VA Power Supply with Three 100VA Class 2 Outputs, 480/277/240/120 Vac to 24 Vac

PSMN300A

Open Style 300VA Power Supply with Three 100VA Class 2 Outputs, 480/277/240/120 Vac to 24 Vac

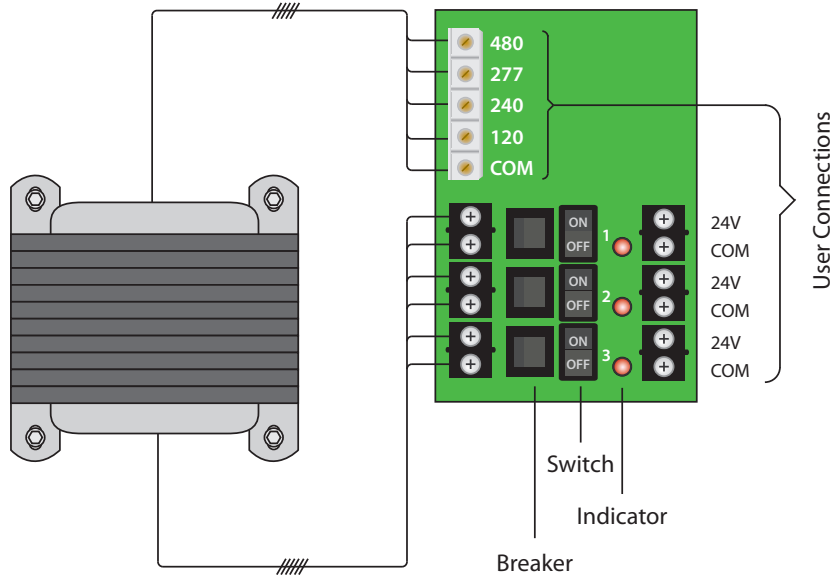

PSH300A Shown With Cover



PSH300A Shown Without Cover

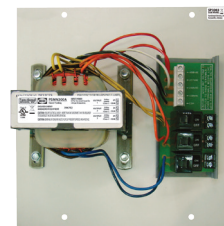

PSMN300A

POWER SUPPLIES

SPECIFICATIONS

Transformer: One (1) 300 VA
Over Current Protection: Circuit Breaker
Primary: 480/277/240/120 Vac
Frequency: 50/60 Hz
Dimensions: 12.125" x 12.125" x 6.000" (PSH300A)
 11.330" x 11.400" x 4.500" (PSMN300A)
Approvals: Class 2 (UL Approved UL5085-3), UL916, UL508, C-UL, [^] Seismic Certification of Equipment and Components: OSP-0201-10 Plenum
Sub-Panel: Rated Polymetal Sub-Panel (PSMN300A)
Housing: NEMA1 Metal Enclosure (PSH300A)
Weight: 20.00 lbs. (PSH300A)
 11.00 lbs. (PSMN300A)

3 Secondaries:
 24 Vac, with LED Indicators
 4 Amp breaker for each output
24 Vac ON/OFF:
 On / Off Switch & Breaker

Input:
 480/277/240/120 Vac Finger-Safe Terminals,
 8-18 AWG

Output:
 3 Ungrounded, Isolated, 100 VA, Class 2, 24 Vac Outputs. Terminals accept 12-26 AWG wire.

Ambient Temperature Derating:
 4A up to 40° C ; 3A up to 50° C ; 2A up to 55° C
 (When All 3 Outputs Operated Simultaneously)

- Notes:**
- To order UL508, add "-IC" to end of model number.
 - Open style (PSMN300A) is mounted to sub-panel SP3303 for shipping. Sub-panel may be removed to suit application.
 - Primary voltage terminal cover available. See model AP553-TC on page 141.
 - Design is in accordance with ASCE 7-05 Chapter 13: [^] www.oshpd.ca.gov/FDD/Pre-Approval/OSP-0201-10.pdf

Standby Wattage:
 16.61 W @ 120 Vac
 17.70 W @ 240 Vac
 16.26 W @ 277 Vac
 19.20 W @ 480 Vac

Full Load Primary Current:
 2.66 A @ 120 Vac
 1.36 A @ 240 Vac
 1.18 A @ 277 Vac
 0.68 A @ 480 Vac

Secondary Output Voltage vs. Load:
 24.5 V @ 1 Amp
 23.5 V @ 2 Amp
 22.8 V @ 3 Amp
 22.3 V @ 4 Amp

- With 120 Vac primary input voltage
- When all 3 outputs operated simultaneously, at room temperature

GREAT FOR VAV APPLICATIONS